

PRESS RELEASE

Mönchengladbach, September 14, 2022

New Cleaning Section for Cleveland Cliffs Kote in New Carlisle, Indiana, USA

Cleveland-Cliffs is the largest flat-rolled steel producer in North America. Founded in 1847 as a mine operator, Cliffs is also the largest producer of iron ore pellets in North America. Meanwhile, they employ more than 26,000 people across its mining, steel and downstream manufacturing operations in the United States and Canada.

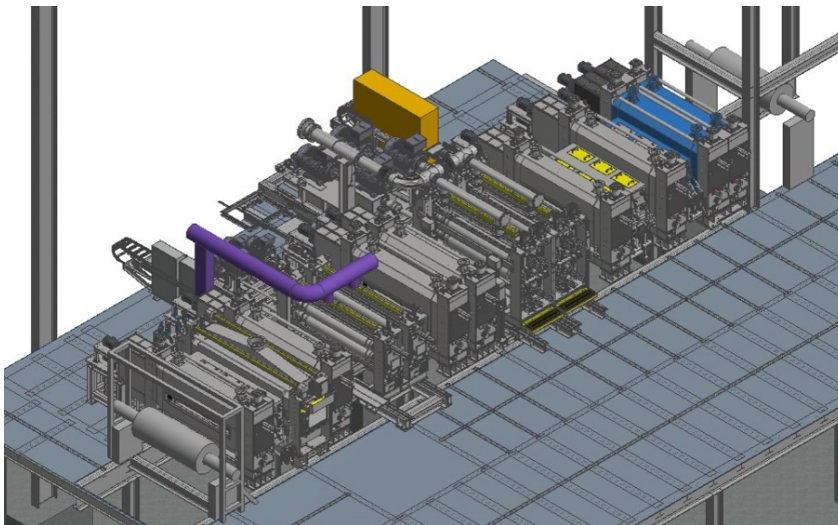

At the plant in New Carlisle they produce hot-dipped galvanized and galvanized Sheets, electrogalvanized coils and cold-rolled sheets and annealed sheets for the automotive industry.

DUMA-BANDZINK will replace the existing cleaning section at Continuous Galvanizing Line (CGL#1). We will deliver a full cleaning section, consisting of alkali section with spray electrolytic cleaning, oscillating alkali brushes and a hot water Section with oscillating abrasive brushes and final rinse.

The cleaning section brings about the following advantages:

- Highest cleaning efficiency with compact design in a horizontal configuration
- Easy and safe maintenance, roll change can be done safely from Operator Side using one single Roll Exchange Cart for all Brush and Wringer Rolls
- Oscillation function extends brush lifetime by more even brush wear
- Abrasive brushes with high brushing power allow cleaning high strength steel grades
- German/European standards

The equipment will be delivered in autumn 2023 and the implementation is planned for end of 2023. DUMA-BANDZINK is proud of its second cleaning section reference in North America!